

ITEM NO.	PART NUMBER	RAW MATERIAL	QTY.
1	Slk 65 Hub	PA6	1
2	Slk 65 CPin	Mild Steel	1
3	Slk 65 Wheel	PA6	2
4	Lock Ring	Spring Steel	1
5	Stem	Mild Steel	1

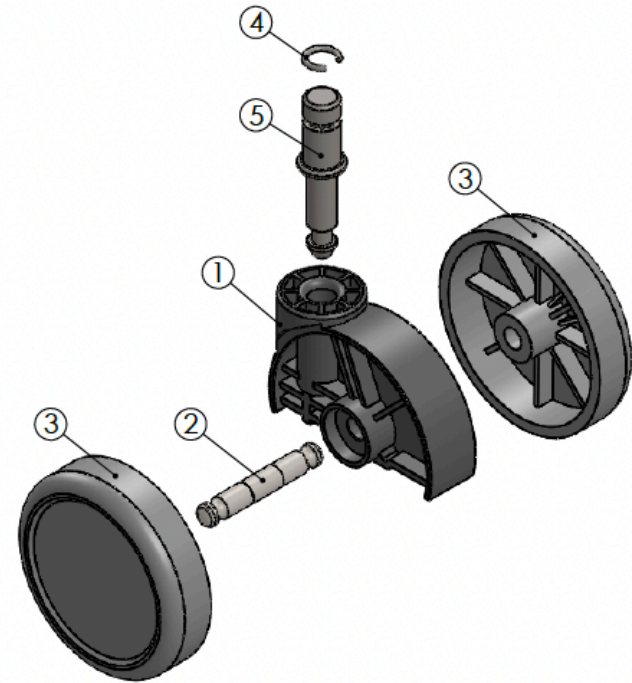
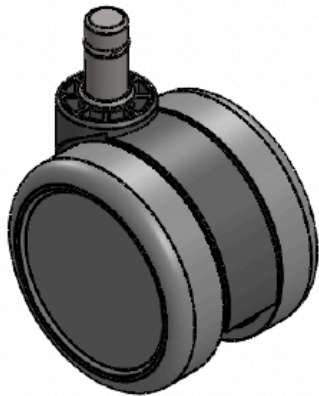
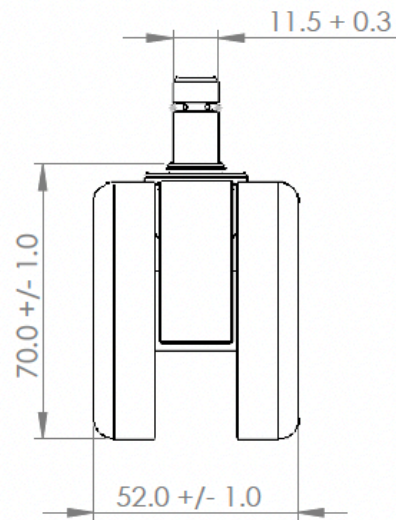
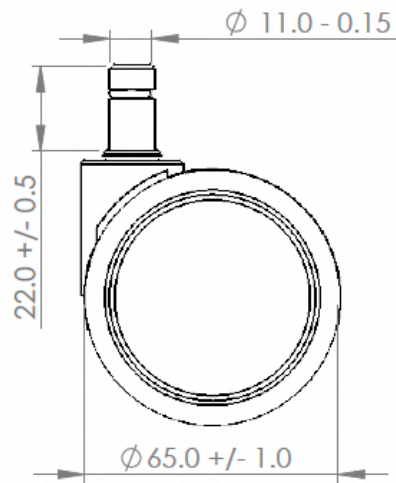
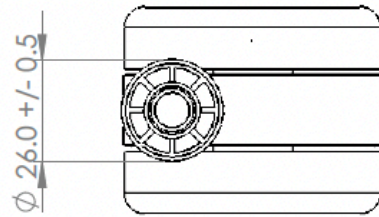

Specifications In Accordance With

EN 12527 / 12528 / 12529

BIFMA x 5.1 2017

Recycle Material Not more than 20%

1RI-C6526BK
Caster 65mm Black 26mm Barrel Hard Wheel

